

OPERATION AND SERVICE MANUAL

VARIBELL®

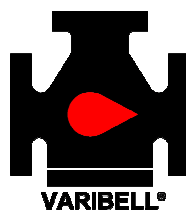

Safety notes

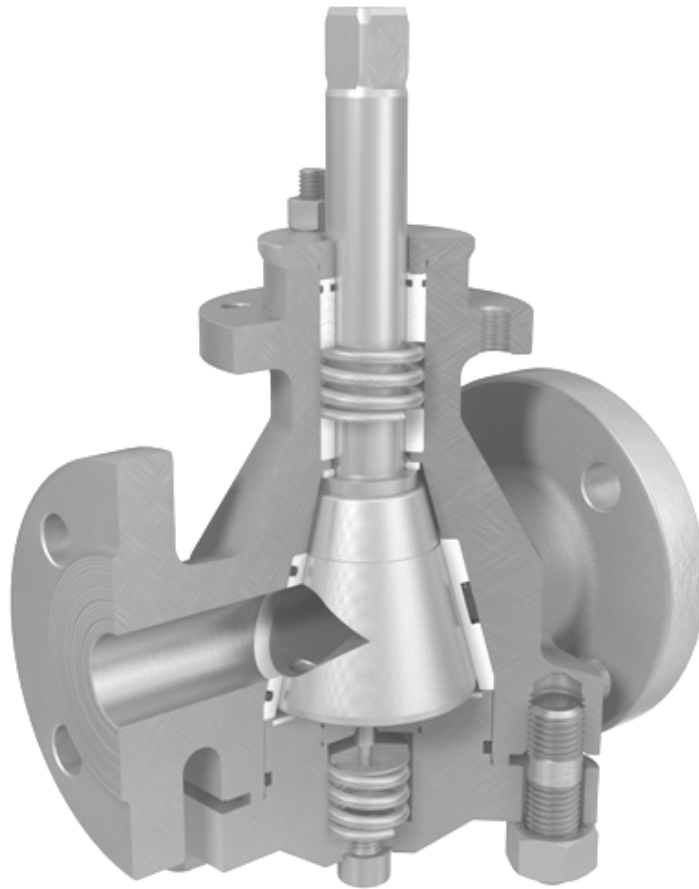

Attention: due to heat transfer from media, the valve may have high surface temperatures!



The maximum surface temperature allowed for the respective ATEX-zone in which the valve is installed, must be taken into account. Any markings on the valve as well as the peripheral devices must be obeyed!
Limit temperatures acc. EN 13463-1 are mandatory!



The control valve needs to be protected against dust and dirt.



Incorrect installation, maintenance or overhaul can lead to the exit of hot, harmful and environmentally harmful media.



Prior to working on the valve, all relevant precautions need to be made and approvals must be obtained. See RL 1999/92 / EC
Prior to welding, the pipeline must be rinsed with inert media!

The control valve is a pressure vessel!
Improper opening may endanger the environment and health!

The valve is to be secured by suitable measures for equipotential bonding against sparking!
These can occur due to static charge or external conditions (high-voltage cables, lightning, etc.).

VARIBELL®

Table of content

1	General information	4
1.1	Technical specifications	4
1.2	Safety information	5
1.3	Special information for explosive areas.....	5
1.4	Information for <i>TA-Luft</i> certified valves.....	6
1.5	Scope of delivery.....	6
2	Transport, storage and return.....	6
2.1	Transport	6
2.2	Storage.....	6
2.3	Return.....	6
3	Product description	7
4	Installation.....	7
5	Operation	8
6	Service.....	8
6.1	Disassembly	9
a)	Removing the bottom flange (20)	9
b)	Removing the bell (2)	9
c)	Removing the seat (6).....	9
d)	Removing the shaft (4).....	9
e)	Removing the packing (28) and guide bushing (7)	10
6.2	Cleaning and maintenance	10
6.3	Assembly.....	11
a)	Installation of packing (a)	11
b)	Installation of seat (6)	11
c)	Installation of shaft (4) and bell (2)	11
d)	Installation of bottom flange (20).....	12
6.4	Spare parts	12
7	Faults	13
8	Drawings	14
9	Parts list.....	16

1 General information

Carefully read this manual before assembly, operation or service. It contains basic notes, which are to be observed during assembly, operation or service of the Varibell® control valve.

1.1 Technical specifications

Manufacturer:

EPC - Equipment for Power Plants and Chemical Industry
IZ NÖ SÜD, Straße 1, Objekt 50, Office D
2355 Wiener Neudorf
AUSTRIA
Tel.: +43 (0)2236 61466 - 0
Fax: +43 (0)2236 61466 - 30
E-mail: epc@epc.at
Web: www.varibell.com

Label:

The label is engraved onto the mounting bracket. The design of the label may differ from the one printed below depending on the valve type. Regarding content, following data is specified on the label:

"Customer"		"Customer order number"	
EPC-Reference:		"A-Number"	
Type:	"Classification"		
Article number:		"Article number"	
DN/ASME:	"NPS"	PN/ANSI:	"pressure rating"
KVS:	"KVS"	PT (bar g):	"test pressure"
PS (bar g):	"max pressure"	TS (°C):	"max temp"
TAG-Number:		"TAG-Number"	
Produced: "year"			

Sizes and pressure ratings:

PN40: DN15, 25, 40, 50, 80, 100, 150

Higher pressure ratings:

DN 15 (½"): PN 63 - 325
DN 25 (1"): PN 63 - 400 / ANSI 2500
DN 40 (1½"): PN 160
DN 50 (2"): PN 63 - 160 / ANSI 900
DN 80 (3"): PN 63 - 100 / ANSI 600

Flow direction:

The standard design of the Varibell® control valve allows both directions of flow to be used, even alternating between them during operation.

Exception: special designs, which are separately marked, e.g. designs with cavitation reducing components.

1.2 Safety information

Installation, commissioning and service may only be carried out by qualified staff. Qualified staff is staff which is familiar with the assembly, installation and servicing of valves through their profession.

Ensure that work is carried out in a way that it doesn't endanger the safety of the staff working as well as avoiding damage to the valve and/or other installations.

All labels affixed to the valve must be observed. **Disregarding the safety instructions results in the loss of any damage claims.**

Check, that the operating conditions mentioned on the label are consistent with the actual operating conditions.

Prior to installation, service or repair verify that the electrical, pneumatic or hydraulic supply lines are switched off by qualified staff and are prevented from being switched on again.

Also ensure that the valve is depressurised, cooled off and drained.

Not complying with this safety information can lead to serious injury as well as damage to the valve and surroundings.

Disregarding these instructions can result in serious injury or damage of property.

Exiting media can pose a danger to the environment and health. Therefore, all relevant rules of occupational health and safety must be obeyed for the respective work area!



1.3 Explicit notes for explosive areas

Varibell® control valves are principally certified for operation in explosive areas and comply with the conformity assessment procedure declared in the EC guideline 94/9/EG (ATEX).

Within the scope of this conformity assessment a risk assessment report in compliance with EN 13463 was created. This report can be provided upon request.

All actuators, as well as electrically operated peripheral devices must comply with the applicable safety regulations as well as the ATEX regulations.

The control valve has to be earthed. In the simplest case this can be achieved using the pipeline screws or the screws on the mounting bracket.

For repairs or revisions, the control valve must be moved out of the explosive area.

Only certified tools may be used for installation of the control valve in explosive areas.

1.4 Information for *TA-Luft* certified valves

Complying with this operation and service manual is a requirement for the validity of the *TA-Luft* certification.

Regular maintenance intervals are to be observed. All tightness relevant screw connections are to be checked and to be tightened as necessary.

1.5 Scope of delivery

The Varibell® control valve is assembled according to the purchase order, inspected and carefully packaged. Upon arrival use the delivery note to check for completeness of the delivery as well as any transportation damage.

2 Transport, storage and return

2.1 Transport

The valve is shipped with protective caps on the flanges. These are not to be removed until immediately before installation. These caps protect the sealing surfaces from dirt and mechanical damages.

2.2 Storage

The valve has to be stored properly if not installed immediately after delivery.

The valve has to be stored in a place with low humidity as well as a constant temperature, protected from environmental influences.

2.3 Return

Mechanically and/or electrically sensitive devices may be mounted on the Varibell® control valve. Thus one has to ensure proper packaging when returning the valve for inspection or repairs. Pay attention to a favourable weight distribution.

Before sending valves back to the manufacturer they have to be cleaned. The inspection or repair will not be carried out otherwise.

VARIBELL®

3 Product description

Varibell® control valves are precise control devices which are manufactured according to AD2000/DGRL 2014/68/EU. All processes are subject to the quality assurance system ISO 9001.

The control is done through a 90° swivel movement as in conventional quarter turn valves.

Contrary to conventional quarter turn valves Varibell® does not only offer the advantage of high control accuracy but also that the internal parts, such as

- Bell (2)
- Seat (6)
- Shaft (4)

can be inspected without removing the valve from the piping system. Actuators and accessories are parameterized prior to delivery, so they don't have to be adjusted afterwards.

4 Installation

Prior to installation the valve has to be checked for any transportation damage. Damaged valves must not be installed.

The required installation length can be found in the dimensional drawing included in the documentation.

To protect the sealing surfaces from damages the protective caps may only be removed immediately before installing the valve.

The piping system should be thoroughly cleaned to remove any contamination.

Note that the piping system fits without implying stresses, angular, center and length offset. Use appropriate seals, screws and nuts only.

The Varibell® control valve has generally no specified mounting position. Note that certain actuators or peripheral equipment may require a specified mounting position. For better accessibility in later revisions it is recommended that the valve is mounted with a horizontal shaft.

Prior to working on the valve, make sure that the actuator is secured from unintentional movement.

VARIBELL®

5 Operation

The Varibell® control valves are tested using water or nitrogen gas. Unless otherwise agreed there may be some residual amount of water inside the valve. Possible reaction with the operating medium is to be kept in mind.

Hex nuts (M) on the bottom flange have to be checked prior to initial installation

Ensure that the permissible operating data are not exceeded. The permissible operating data can be found on the label engraved in the mounting bracket.

6 Service

Installation, commissioning and service may only be carried out by qualified staff. Qualified staff is staff which is familiar with the assembly, installation, and servicing of valves and are skilled through their occupation.

Always wear suitable protective equipment and pay attention to potentially dangerous media in the valve or pipe.

Always ensure that work is carried out in a way that doesn't endanger the safety of the staff working as well as avoiding damage to the valve and other property.

Attention:

Before attempting any inspection or service work ensure that the valve is unpressurized, cooled off and drained.

Verify that the electrical, pneumatic or hydraulic supply lines are switched off by qualified staff and are prevented from being switched on again.

All surfaces of the internal parts are machined to very tight tolerances. Appropriate care must be taken when working with these parts.



VARIBELL®

6.1 Disassembly

a) Removing the bottom flange (20)

Loosen the hex nuts (K) and if installed the retaining bush on the gland flange. That way any residual pressure in the top part of the valve can escape and removing the shaft (4) later on will not damage the packing (28).

Unscrew the hex nuts (M) on the bottom flange only to the end of the double ended stud (S). This allows any residual pressure in the bottom part of the valve to escape.

If the bottom flange (20) doesn't get pushed out by the spring (F1), **do not remove the hex nuts (M) completely**. Carbonization on the bottom flange can cause it to stick. Residual pressure can cause the bottom flange to suddenly move which poses a serious risk of injury.

If the bottom flange doesn't get pushed out by the spring, there is a groove between the valve body (1) and the bottom flange where a tool can be inserted to lever the bottom flange out.

Then one by one remove the hex nuts and finally the bottom flange.

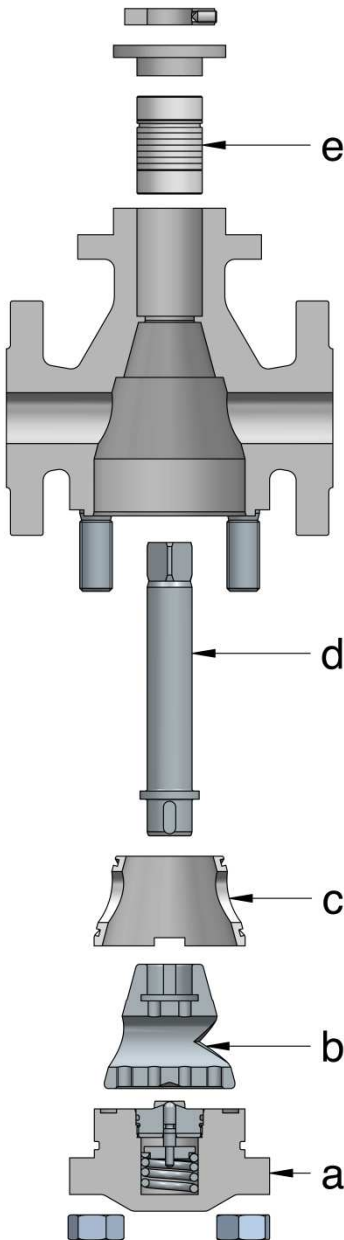

b) Removing the bell (2)

There are two threaded holes on the bottom of the bell:

DN 15 VE	M6
DN15 b	M8
DN 25	M8
DN 40	M10
DN 50	M10
DN 80	M16
DN 100	M16
DN 150	M16

Standard threaded rods can be inserted to remove the bell from the valve.

c) Removing the seat (6)

Carefully grab the seat at the pipe opening and slide it out.

d) Removing the shaft (4)

Loosen the travel indicator (15) (headless pin (G)) and slide it upwards. Carefully slide the shaft (4) downwards out of the valve.

e) *Removing the packing (28) and guide bushing (7)*

Only if necessary. The parts inner surface can be inspected optically (after removing the shaft (4) inside the valve).

Removal: Press packing and guide bushing out of the valve body.

6.2 Cleaning and maintenance

Damaged parts need to be replaced or when possible reworked.

To ensure rapid processing of replacement part orders make sure to specify the order number. This number is engraved into the mounting bracket as well as stamped into the valve body and bottom flange.

Part numbers can be found in the appropriate bill of materials included with the valves documentation.



6.3 Assembly

Prior to assembly all part need to be well cleaned.

a) Installation of packing (a)

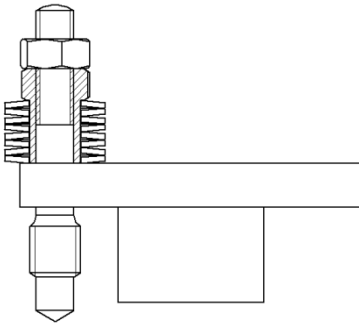

For PTFE Packings (28) observe the correct orientation of the packing rings. Operating pressure needs to spread those outwards (see attached cutaway drawing). A special form is used for vacuum applications.

Slide the single layered Plate springs (T) onto the retaining bush (27). Screw the retaining bush to the double ended stud.

Tighten hex nut (K). Allow for enough remaining spring travel.

Attention: Do not tighten Packing (a) before inserting the shaft (4). If the medium permits it, all O-Rings should be greased with O-Ring grease.

b) Installation of seat (6)

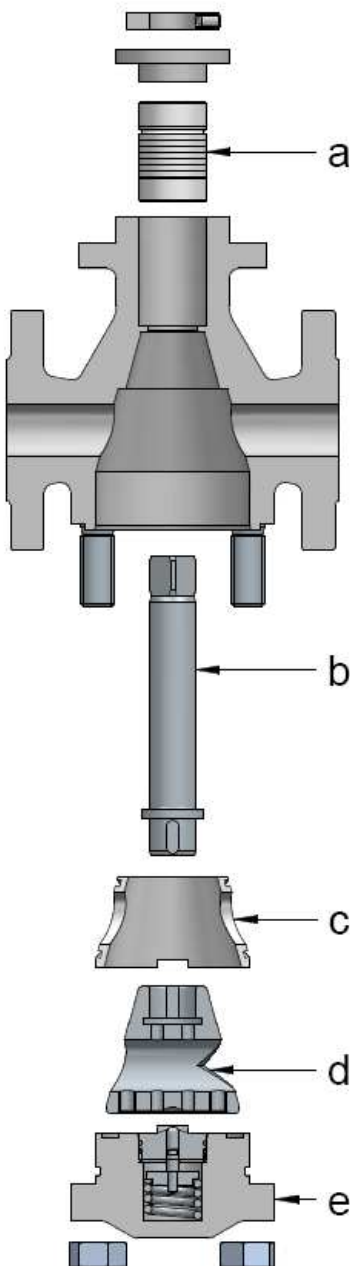

Visually align the seat (6) by the pipe openings of the valve body (1). The seat should slide into the valve body easily. Should this not be the case it is recommended for metal and PEEK seats to carefully and uniformly grind the cylindrical outer diameter of the seat until it slides easily into the valve body.

Seats have two grooves on the shell surface into which O-Rings are inserted. O-Ring grease can be used to keep them from dropping out (if the medium permits it).

c) Installation of shaft (4) and bell (2)

Check the old step bearing (21) for wear and replace as necessary.

Carefully insert the shaft (4) into the packing until the step bearing (21) touches the valve body (1).

Attention: Be careful when inserting the shaft as sharp edges may damage the inner O-Ring of the packing. If permitted by the medium, use O-Ring grease.

Slide the bell (2) onto the shaft (4) until the sunk key (E) engages fully.

Attach the travel indicator (15) onto the shaft and align it with the position of the bell. Set it in place with the headless pin (G).

VARIBELL®

d) Installation of bottom flange (20)

A pin (P) is used to align the bottom flange (20) and the valve body (1). The seat (6) is centered and locked in place using two tongue and groove profiles. See image on the left.

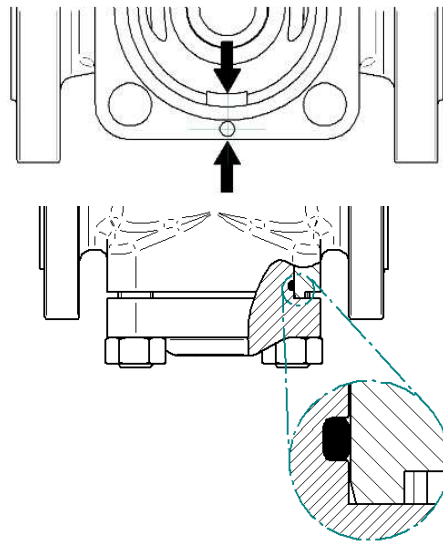

Installation of the bottom flange without positioning tube: the sealing gasket sits directly above cover plane surface.

For assembly and/or repairs of the actuator and accessories refer to the specific instructions.

Installation of the bottom flange with positioning tube: Check sealing ring (40) - unscrew the two screws (GS) slots of the positioning tube (5), pull off the positioning tube and examine the sealing ring. If necessary install a new sealing ring. Upon reassembly, check for light movement of the positioning tube within the slot. Insert the gliding ring (22) in the appropriate groove on the bottom flange.

The bottom flange should slide into the valve body easily, as the sealing ring only engages at the last few tenths of a millimeter. This allows for easy installation without damaging the O-Ring.

Finally screw on the hex nuts (M). The used torque does not affect the total valve tightness, but a torque of approximately 70Nm is recommended to prevent unintentional loosening of the nuts.

Caution: Do not use force to tighten the nuts in case of an unusual increase in torque. This may be the result of a misaligned valve seat and can lead to a damaged seat and/or bottom flange.

6.4 Spare parts

To ensure rapid processing of replacement part orders make sure to specify the order number. This number is engraved into the mounting bracket as well as stamped into the valve body and bottom flange.

Part numbers can be found in the appropriate bill of materials included with the valves documentation.

7 Faults

Attention: Before attempting any inspection or service work ensure that the valve is unpressurized, cooled off and drained. Noncompliance might lead to serious injury and/or damage to the valve and surrounding property.

Prior to installation, service or repair verify that the electrical, pneumatic or hydraulic supply lines are switched off by qualified staff and are prevented from being switched on again.

For faults with the actuator or other peripherals refer to the particular operating manual.

- **Leaking gland flange**

For TA-Luft designs:

Tighten the retaining bush (27) and lock nut (K). Make sure that to leave enough remaining spring travel. Consider replacing the packing (28) at the next maintenance interval.

For standard design:

Check that the retaining bush is in even contact with the valve body. If this is not the case, tighten the hex nut (K). Consider replacing the packing (28) at the next maintenance interval.

- **Leaking flange connection at valve body / bottom flange**

Check the tightening torque of the hex nuts (M). If that does not solve the problem, the bottom flange seal (40) needs to be replaced.

- **Valve not opening / closing completely**

Please check the following information:

Is the actuator sized properly and are the stop positions adjusted accordingly?

Is the air pressure high enough? Is the positioner initialized correctly?

Wear in the valve can lead to an increase of the required torque.

- **Control quality not according to specification**

Wear of the control slot due to cavitation or abrasive media can lead to a loss in control quality.

Check for hysteresis between the bell, shaft and actuator.

Compare the operational data listed when ordering the valve to the actual operational data (Inlet- and outlet pressure, temperature, viscosity, media and flow rate).

8 Drawings

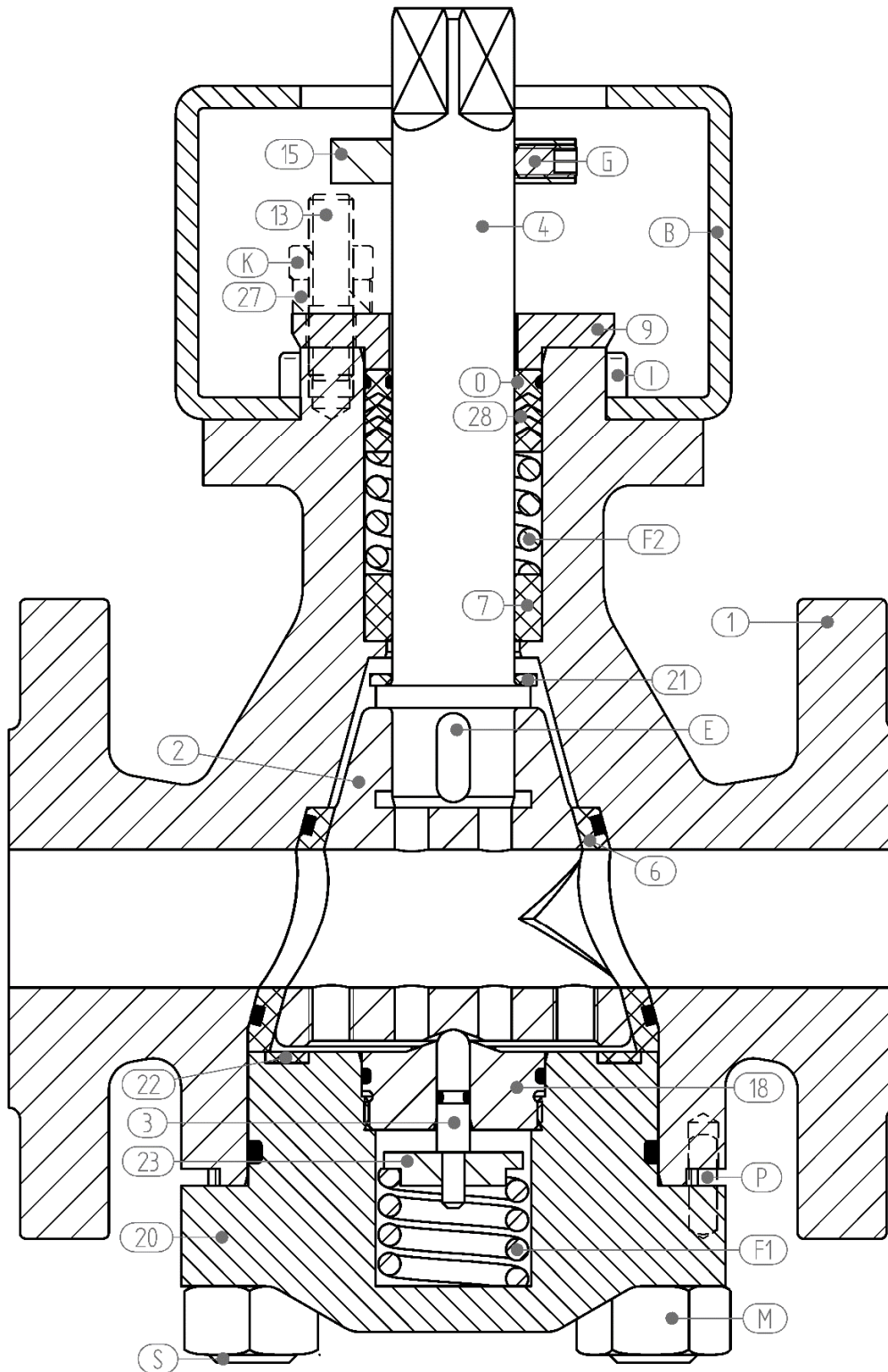

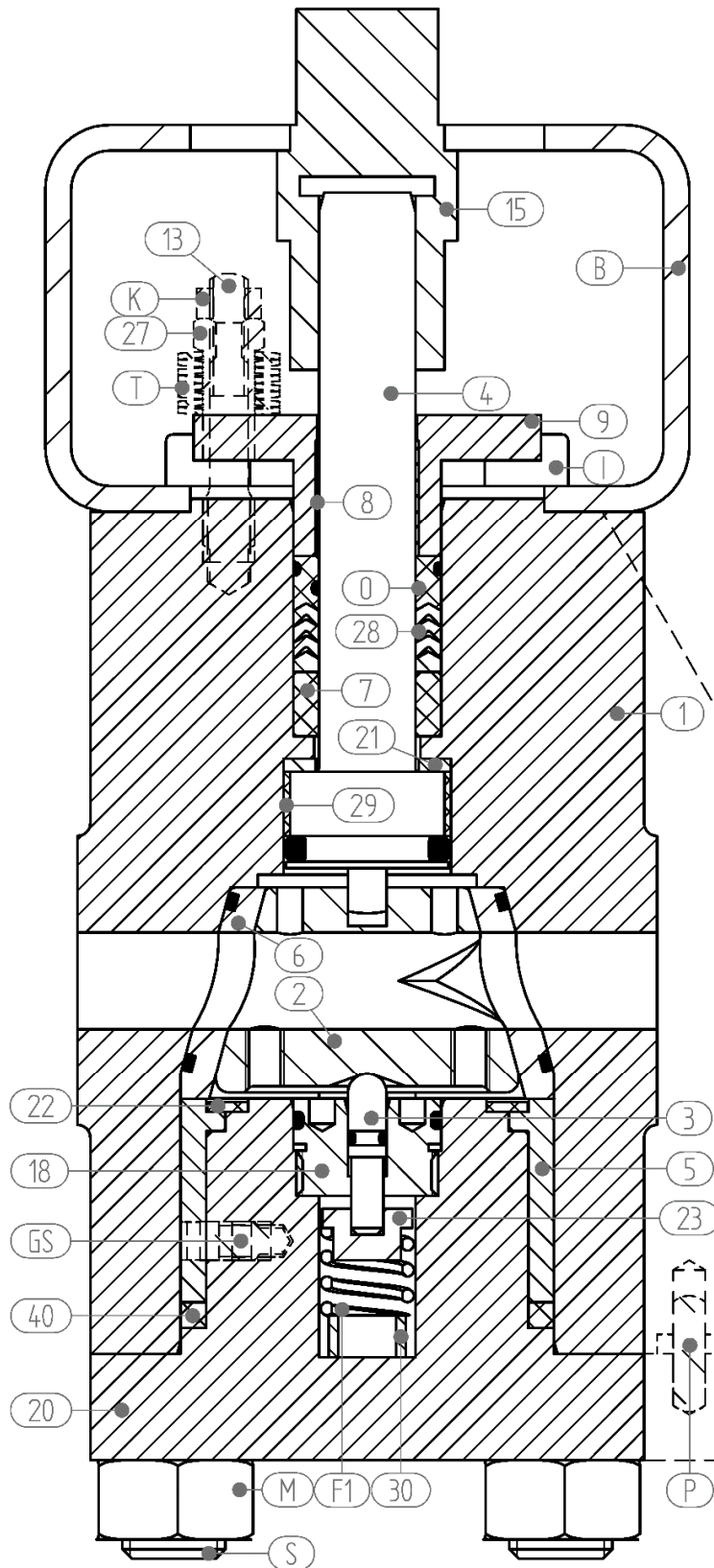

9 Parts list

1	Body
2	Bell
3	Set bolt
4	Shaft
5	Positioning tube
6	Seat
7	Guide bush
8	Guide bush
9	Gland flange
13	Double ended stud
15	Travel indicator
18	Spring washer
20	Bottom flange
21	Step bearing
22	Gliding ring
23	Spring plate
27	Retaining bush
28	Packing
29	Guide bush
30	Spacer
40	Bottom flange seal
B	Mounting bracket
E	Round ended sunk key
F1/F2	Spring
G	Headless pin
GS	Threaded pin
I	Socket head cap screw
K	Hex nut
M	Hex nut
O	O-Rings
P	Pin
S	Double ended stud
T	Disk springs